



INDUSTRIAL MAGZA
DIST. AUTORIZADO

MEX (55) 53 63 23 31 MTY (81) 83 54 10 18
QRO (442) 1 95 72 60 ventas@industrialmagza.com

nexen®

AIR CHAMP® PRODUCTS

User Manual

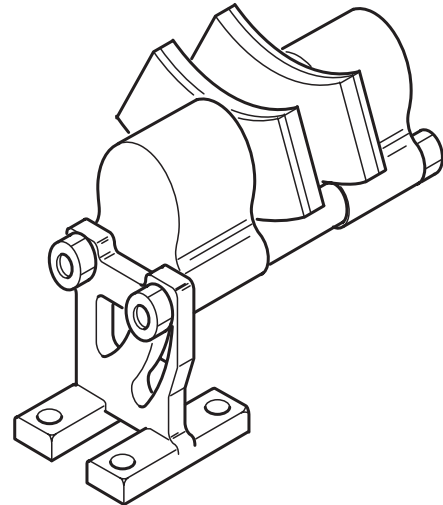
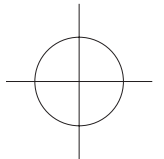

Model DB Disc Caliper Brake



INDUSTRIAL MAGZA
DIST. AUTORIZADO

MEX (55) 53 63 23 31 MTY (81) 83 54 10 18
QRO (442) 1 95 72 60 ventas@industrialmagza.com

In accordance with Nexen's established policy of constant product improvement, the specifications contained in this manual are subject to change without notice. Technical data listed in this manual are based on the latest information available at the time of printing and are also subject to change without notice.

Technical Support:
800-843-7445
(651) 484-5900

www.nexengroup.com



WARNING

Read this manual carefully before installation and operation.

Follow Nexen's instructions and integrate this unit into your system with care.

This unit should be installed, operated and maintained by qualified personnel **ONLY**.

Improper installation can damage your system or cause injury or death.

Comply with all applicable codes.

Nexen Group, Inc.
560 Oak Grove Parkway
Vadnais Heights, Minnesota 55127

Table of Contents

Introduction.....	1
Installation	1
Air Connections	2
Lubrication.....	2
Friction Facing Replacement	3
Parts List	4
Replacement Parts	4
Warranties	5

INTRODUCTION

Read this manual carefully, making full use of its explanations and instructions. The "Know How" of safe, continuous, trouble-free operation depends on the degree of your understanding of the system and your willingness to keep all components in proper operating condition. Pay particular attention to all NOTES, CAUTIONS, and WARNINGS to avoid the risk of personal injury or property damage. It is important to understand that these NOTES, CAUTIONS, and WARNINGS are not exhaustive. Nexen cannot possibly know or evaluate all conceivable methods in which service may be performed, or the possible hazardous consequences of each method. Accordingly, anyone who uses a procedure that is not recommended by Nexen must first satisfy themselves that neither their safety or the safety of the product will be jeopardized by the service method selected.

INSTALLATION

NOTE: The Brake Disc (ordered separately) may be mounted to a customer supplied hub or mounted to the Nexen Disc Brake Hub (also ordered separately) for use with a Q.D. Bushing.

1. Apply a drop of Loctite® 242 to the threads of the six Flat Head Hex. Socket Cap Screws provided with the Brake Disc and secure the Brake Disc to the Brake Disc Hub or to a customer supplied hub (See Figure 1).
2. Alternately and evenly tighten the six Flat Head Hex. Socket Cap Screws to the recommended torque (See Figure 1 and Table 1).
3. Thoroughly inspect the tapered bore of the Brake Disc Hub and the tapered surface of the Q.D. Bushing. Remove any dirt, grease, or foreign material. Do not use lubricants for this installation.
4. Assemble the Q.D. Bushing into the Brake Disc Hub, aligning the untapped holes in the Q.D. Bushing with the tapped holes in the Brake Disc Hub.

NOTE: Runout is minimized if a Dial Indicator is used as the pull-up bolts are tightened. Place the contact tip of the Dial Indicator on the machined surface of the Brake Disc to measure runout. Runout should be less than 0.010-0.015 In. [0.254-0.381 mm] (See Figure 2).

CAUTION

If excessive tightening torque is applied, bursting pressures are created in the Brake Hub. There must be a gap between the flange of the Q.D. Bushing and the Brake Disc to ensure a proper fit of the Q.D. Bushing onto the shaft.

5. Insert the pull-up bolts; then, alternately and evenly tighten them to 15 Ft. Lbs. [20.3 N•m] torque.
6. To remove the Q.D. Bushing, remove the pull-up bolts; then, reinsert them into the threaded holes of the Q.D. Bushing. Tighten the pull-up bolts to push

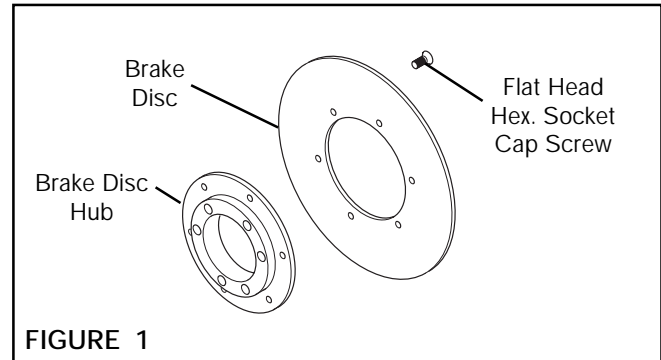

FIGURE 1

TABLE 1

RECOMMENDED TIGHTENING TORQUES FLAT HEAD HEX. SOCKET CAP SCREWS	
MODEL	TIGHTENING TORQUE
10 In. Disc (Prod. No. 855500)	45 In. Lbs. [5.04 N•m]
12 In. Disc (Prod. No. 855600)	105 In. Lbs [11.76 N•m]
14 In. Disc (Prod. No. 855700)	105 In. Lbs [11.76 N•m]
16 In. Disc (Prod. No. 855800)	105 In. Lbs [11.76 N•m]

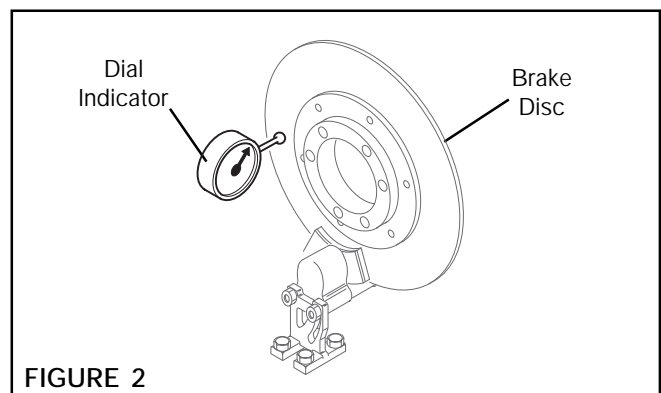
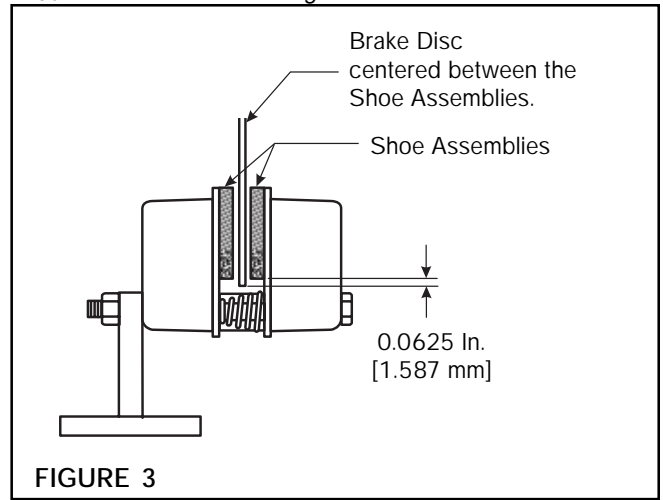
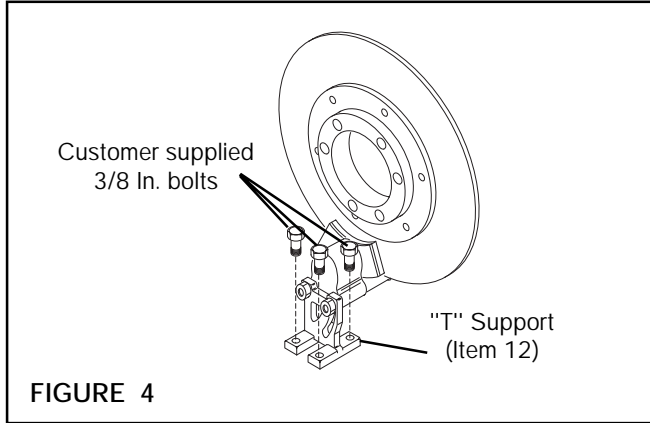

FIGURE 2



7. Mount the Caliper Brake so the radius of the Disc runs approximately 0.0625 In. [1.587 mm] below the outside radius of the Shoe Assembly (Item 1), and with an equal distance between the Disc and the Shoe Assemblies (See Figure 3).
8. Use customer supplied 3/8 In. bolts to mount the "T" Support (Item 12) to a solid base (See Figures 3 and 4).



AIR CONNECTIONS

Each Air Chamber (Item 2) is tapped for 1/8 NPT air connections. Use flexible air lines when making air connections.

NOTE: Nexen recommends using Nexen Air Line Assembly (Product No. 835400) to properly tee the incoming air source to each half of the Model DB - Disc Caliper Brake.

LUBRICATION

NOTE: Pneumatically actuated devices require clean, pressure regulated, and lubricated air for maximum performance and long life. The most effective and economical way to lubricate Nexen Clutches and Brakes is with an Air Line Lubricator, which injects oil into the pressurized air, forcing an oil mist into the air chamber.

Locate the lubricator above and within ten feet of the Clutch or Brake, and use a low viscosity oil such as SAE-10.

Synthetic lubricants are not recommended.

LUBRICATOR DRIP RATE SETTINGS

NOTE: These settings are for Nexen supplied lubricators. If you are not using a Nexen lubricator, calibration must replicate the following procedure.

1. Close and disconnect the air line from the unit.
2. Turn the Lubricator Adjustment Knob clockwise three complete turns.
3. Open the air line.
4. Close the air line to the unit when a drop of oil forms in the Lubricator Sight Gage.
5. Connect the air line to the unit.
6. Turn the Lubricator Adjustment Knob counterclockwise until closed.
7. Turn the Lubricator Adjustment Knob clockwise one-third turn.

FRICITION FACING REPLACEMENT

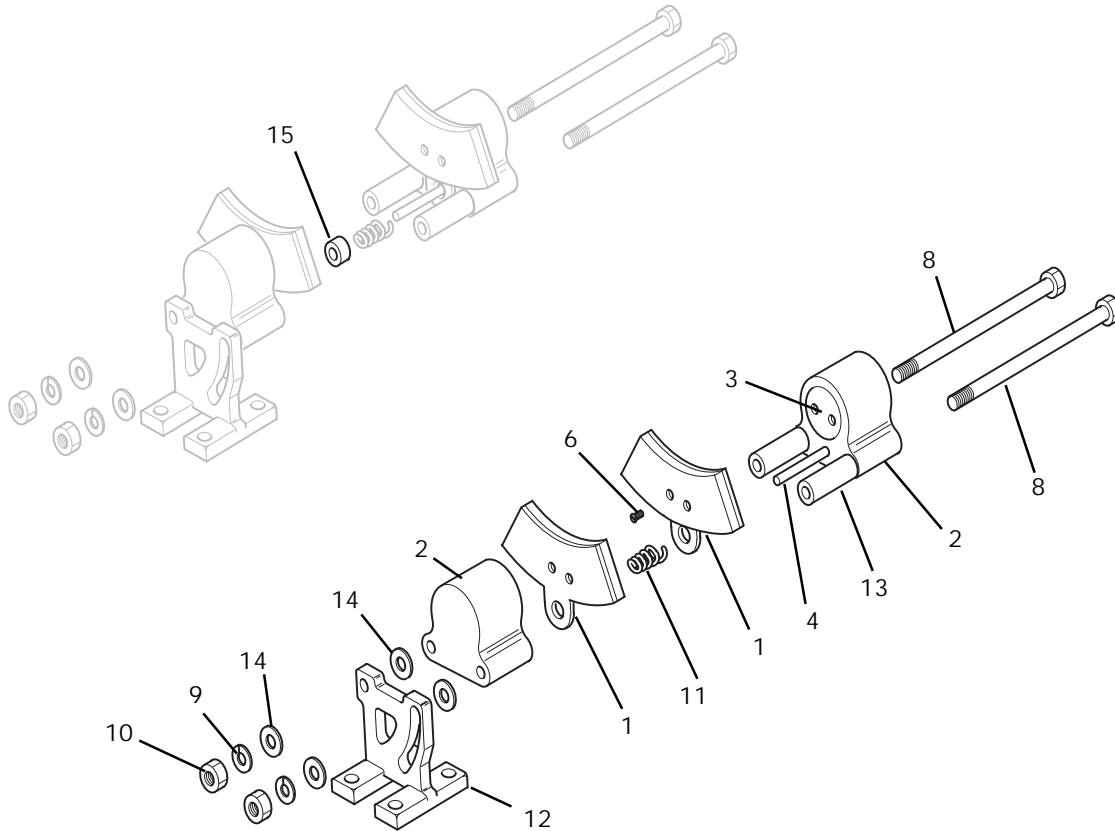

FIGURE 5

1. Remove the two Hex. Head Screws (Item 9), Hex. Nuts (Item 10), Lock Washers (Item 9), and Flat Washers (Item 14); then, remove the two Air Chambers (Item 2) from the "T" Support (Item 12) (See Figure 5).
 2. Separate the two Air Chambers (Item 2) (See Figure 5).
 3. Remove the Flat Head Cap Screws (Item 6) securing the old Shoe Assemblies (Item 1) to the Piston (Item 3) (See Figure 5).
 4. Apply Loctite® 242 to the threads of the Flat Head Screws (Item 6); then, secure the new Shoe Assemblies (Item 1) to the Pistons (Item 3) (See Figure 5).
 5. Tighten the Flat Head Cap Screws to 22 In. Lbs. [2.5 N•m] torque.
- NOTE: Some Model DB-Disc Caliper Brakes use a Spacer (Item 15) that must be installed onto the Guide Pin (Item 4) when the Caliper Brake is reassembled.
6. Slide the Compression Spring (Item 11) onto the Guide Pin (Item 4); then, insert the two Air Chamber Spacers (Item 13) and slide the two Air Chambers together (See Figure 5).
 7. Using the two Hex. Head Screws (Item 8), Hex. Nuts (Item 10), Lock Washers (Item 9), and Flat Washers (Item 14), secure the two Air Chambers (Item 2) to the "T" Support (Item 12) (See Figure 5).

PARTS LIST

BRAKE DISC

ITEM	DESCRIPTION	QTY
1	Brake Disc	1
2	Flat Head Dex. Socket Cap Screw	6

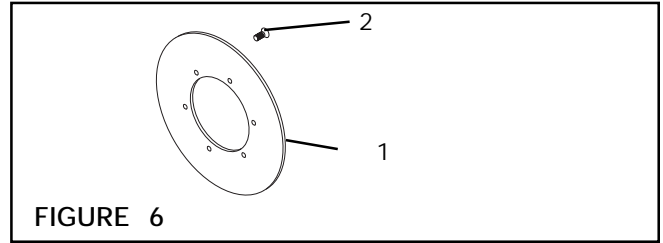

FIGURE 6

BRAKE DISC HUB

ITEM	DESCRIPTION	QTY
1	Brake Disc Hub	1

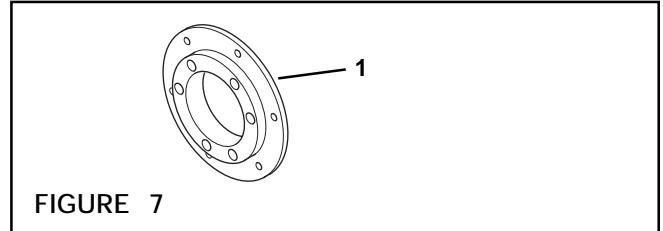

FIGURE 7

DB-DISC CALIPER BRAKE

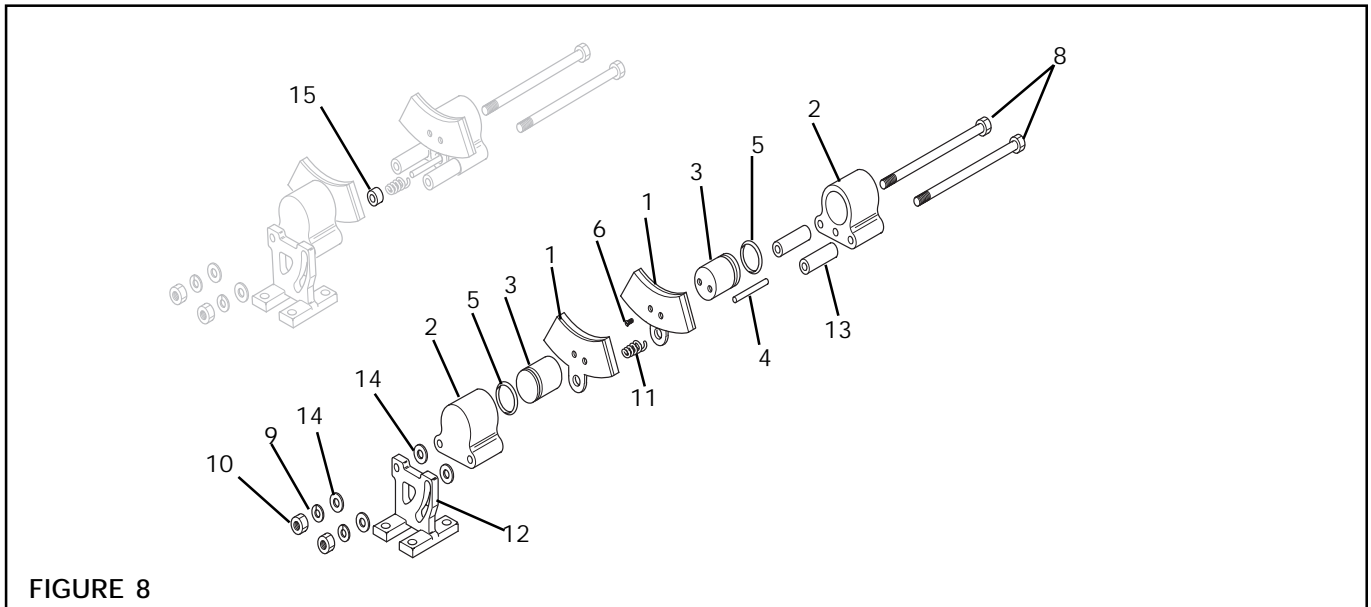

FIGURE 8

ITEM	DESCRIPTION	QTY
1 ¹	Shoe Assembly	2
2	Air Chamber	2
3	Piston	2
4	Guide Pin	1
5	O-ring Seal	2
6	Flat Head Cap Screw	4
8	Hex. Head Screw	2

¹ Denotes Facing Kit Item.

ITEM	DESCRIPTION	QTY
9	Lock Washer	2
10	Hex. Nut	2
11	Compression Spring	1
12	"T" Support	1
13	Spacer	2
14	Flat Washer	4
15 ²	Spacer	1

² Spacer (Item 15) not used on all models.

REPLACEMENT PARTS

The item or balloon number for all Nexen products is used for part identification on all product parts lists, product price lists, unit assembly drawings, bills of materials, and instruction manuals.

When ordering replacement parts, specify model designation, item number, part description, and quantity. Purchase replacement parts through your local Nexen Distributor.



WARRANTIES

Warranties

Nexen warrants that the Products will be free from any defects in material or workmanship for a period of 12 months from the date of shipment. NEXEN MAKES NO OTHER WARRANTY, EXPRESS OR IMPLIED, AND ALL IMPLIED WARRANTIES, INCLUDING WITHOUT LIMITATION, IMPLIED WARRANTIES OF MERCHANTABILITY AND FITNESS FOR A PARTICULAR PURPOSE ARE HEREBY DISCLAIMED. This warranty applies only if (a) the Product has been installed, used and maintained in accordance with any applicable Nexen installation or maintenance manual for the Product; (b) the alleged defect is not attributable to normal wear and tear; (c) the Product has not been altered, misused or used for purposes other than those for which it was intended; and (d) Buyer has given written notice of the alleged defect to Nexen, and delivered the allegedly defective Product to Nexen, within one year of the date of shipment.

Exclusive Remedy

The exclusive remedy of the Buyer for any breach of the warranties set out above will be, at the sole discretion of Nexen, a repair or replacement with new, serviceably used or reconditioned Product, or issuance of credit in the amount of the purchase price paid to Nexen by the Buyer for the Products.

Limitation of Nexen's Liability

TO THE EXTENT PERMITTED BY LAW NEXEN SHALL HAVE NO LIABILITY TO BUYER OR ANY OTHER PERSON FOR INCIDENTAL DAMAGES, SPECIAL DAMAGES, CONSEQUENTIAL DAMAGES OR OTHER DAMAGES OF ANY KIND OR NATURE WHATSOEVER, WHETHER ARISING OUT OF BREACH OF WARRANTY OR OTHER BREACH OF CONTRACT, NEGLIGENCE OR OTHER TORT, OR OTHERWISE, EVEN IF NEXEN SHALL HAVE BEEN ADVISED OF THE POSSIBILITY OR LIKELIHOOD OF SUCH POTENTIAL LOSS OR DAMAGE. For all of the purposes hereof, the term "consequential damages" shall include lost profits, penalties, delay images, liquidated damages or other damages and liabilities which Buyer shall be obligated to pay or which Buyer may incur based upon, related to or arising out of its contracts with its customers or other third parties. In no event shall Nexen be liable for any amount of damages in excess of amounts paid by Buyer for Products or services as to which a breach of contract has been determined to exist. The parties expressly agree that the price for the Products and the services was determined in consideration of the limitation on damages set forth herein and such limitation has been specifically bargained for and constitutes an agreed allocation of risk which shall survive the determination of any court of competent jurisdiction that any remedy herein fails of its essential purpose.

Limitation of Damages

In no event shall Nexen be liable for any consequential, indirect, incidental, or special damages of any nature whatsoever, including without limitation, lost profits arising from the sale or use of the Products.

Warranty Claim Procedures

To make a claim under this warranty, the claimant must give written notice of the alleged defect to whom the Product was purchased from and deliver the Product to same within one year of the date on which the alleged defect first became apparent.

nexen®

Nexen Group, Inc.
560 Oak Grove Parkway
Vadnais Heights, MN 55127

800.843.7445
Fax: 651.286.1099
www.nexengroup.com

ISO 9001 Certified